

EVA-LAST®

INSPIRED BY NATURE, DESIGNED FOR LIFE.

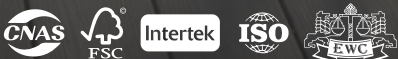

Sustainable Building Materials



www.eva-last.es





A BRAND YOU CAN TRUST

Eva-Last is a globally reputable brand that utilises a solution driven business model to create innovative, sustainable building materials and systems that add value to customers' lives. At the heart of Eva-Last is a team of highly capable, creative specialists united by a passion to promote environmental consciousness through eco-friendly building products and operations. By embracing low environmental impact manufacturing and cutting-edge composite technology, Eva-Last is revolutionising how building can be done. We design and deliver beautiful, long-lasting green alternatives that make our customers' lives easier, healthier, and just plain better.

THE HASSLE-FREE ALTERNATIVE TO WOOD

Eva-Last composite offers the beauty of timber, but in a hassle-free, durable option that's longer lasting, virtually maintenance free, and eco-friendly. Cutting-edge engineering is bringing even greater structural advancements and lifestyle benefits to composite, and thoughtful detail to aesthetics now gives it an even more natural appearance in an expanded range of products, colours, and textures.

Eva-Last technologies create endless possibilities for the design and overall function of your outdoor space. Visit our website, www.eva-last.com, for inspiration and find out more about which composite product will suit your needs best.



PHOTOGRAPHY CREDIT: CHRIS SCOTT | COPYRIGHT
© SCOTTY PHOTOGRAPHY

CONTENTS

High quality, low-maintenance bamboo composite building materials, and new-age building systems.



06-25

DECKING

Eva-Last composite decking is designed to make any outdoor area more beautiful and more enjoyable. Choose from our three specialised bamboo composite decking brands.



26-33

ARCHITECTURAL BEAMS

Lifespan hybrid aluminium composite beams give you the creative freedom to build more memorable outdoor pergolas, screens, and other architectural design features.



34-43

DECK FASTENERS

HULK Fasteners offer higher performance and are a more efficient and discreet way to secure your decking without disrupting its final look.

Disclaimer:

Although we make every effort to ensure the information contained in this brochure is accurate, we are NOT responsible for any errors or misprint that occurs and we are NOT responsible for ANY damage or liability that result from the use (or misuse) of the information. In the event that an error does occur, we reserve the right to correct, or make changes to, this information at any time.

Disclaimer:

Span data provided herein is indicative based on specific test load conditions (refer to your product Technical Data Sheet). Dimensional and mass data provided herein is indicative based on typical production and may vary with manufacture and material tolerance. Before installing any Eva-Last product, ensure that the application is rational and complies with the local regulations and building codes. Wherever necessary, consult a suitably qualified professional.



LOW ENVIRONMENTAL IMPACT

Holistically sustainable manufacturing & use of raw materials

When you choose Eva-Last, you're choosing the best solution for both you and the environment. Eva-Last products are the low-maintenance, reliable alternative to wood that consistently outperform timber and other composite materials. They're also the environmentally friendly material choice that is gentler on the Earth.



BAMBOO WASTES LESS & PROVIDES MORE

Eva-Last uses bamboo in its composite production. Bamboo can grow up to 50 times faster than timber and releases 35 percent more oxygen into our air than most hardwood trees. It can be made into composite with only 2 percent wastage (compared to over 80 percent wastage with timber), and is naturally antibacterial.



USE OF RECYCLED PLASTIC

By using recycled waste plastics, in combination with easily replenishable bamboo fibre, we are able to produce a highly durable composite product while saving millions of tons of plastic from entering landfills and oceans. Every year Eva-Last recycles over 26000 tons of plastic. Recycling one ton of plastic results in carbon dioxide savings of approximately 0.73 tons - the same as travelling 4 000 km in a car.



USE OF SOLAR POWER IN THE MANUFACTURING PROCESS

Traditional manufacturing is an energy-intensive endeavour. That's why Eva-Last took the decision to start moving towards manufacturing using solar energy. Since 2017, 32 858 solar panels, or 88 716 m² of solar panels, have been installed. This leads to a saving of 2 000 tons of CO₂ every single day.

Eva-Last has been at the forefront of the green building industry since its inception in 2007. We are dedicated to consistently improving how we serve the environment and our clients. From the recycled and renewable raw ingredients we use to create our products, to the solar power we harness to manufacture, we are proud to offer holistically sustainable building products.

Holistically sustainable building products, from a globally reputable brand

Apex[®] PLUS

REINFORCED, CAPPED BAMBOO-PVC COMPOSITE

Apex PLUS offers you a resilient and natural looking composite. Its bamboo foamed-PVC and glass fiber-reinforced core allows for increased span capability over Apex. Low-maintenance Apex PLUS is more stable with less expansion and contraction than its predecessor, and requires only basic cleaning for optimal longevity. Its protective cap is made from a resilient acrylic polymer coating, for long-term fade, scratch, and stain resistance. Apex PLUS also provides decay resistance against insects, moisture, and the elements. Apex PLUS is an eco-friendly alternative to timber that prevents deforestation and premature deck replacement and uses solar power within the manufacturing process.

GFR | GLASS FIBER
REINFORCED

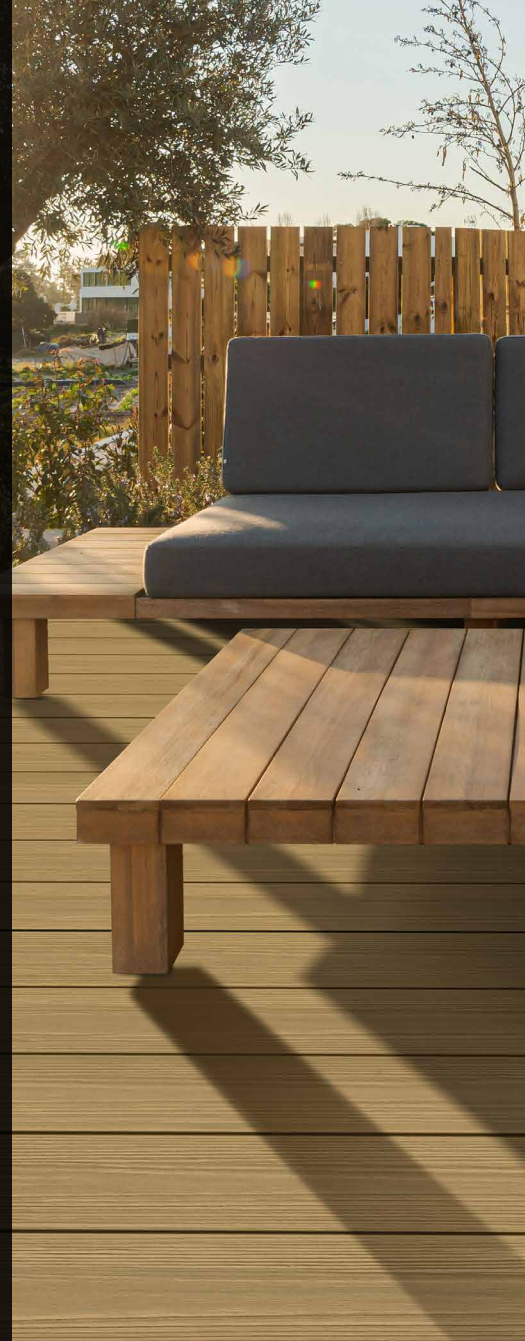

PRODUCT COMPOSITION

Apex[®] PLUS

Apex PLUS upgrades your outdoor space with a cutting-edge composition that is equally beautiful and resilient. Its reinforced core gives you greater design freedom by reducing the amount of substructure your project needs and its specialised composition minimises contraction and expansion for a more stable board.

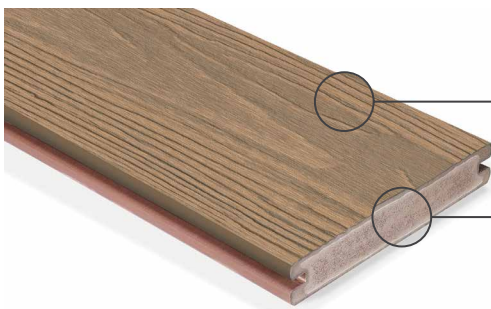

Capping material:
Engineered acrylic polymer

Core material:
Bamboo foamed-PVC composite
with glass fiber-reinforcement

GFR | GLASS FIBER
REINFORCED



FSC[®] certified bamboo composite product

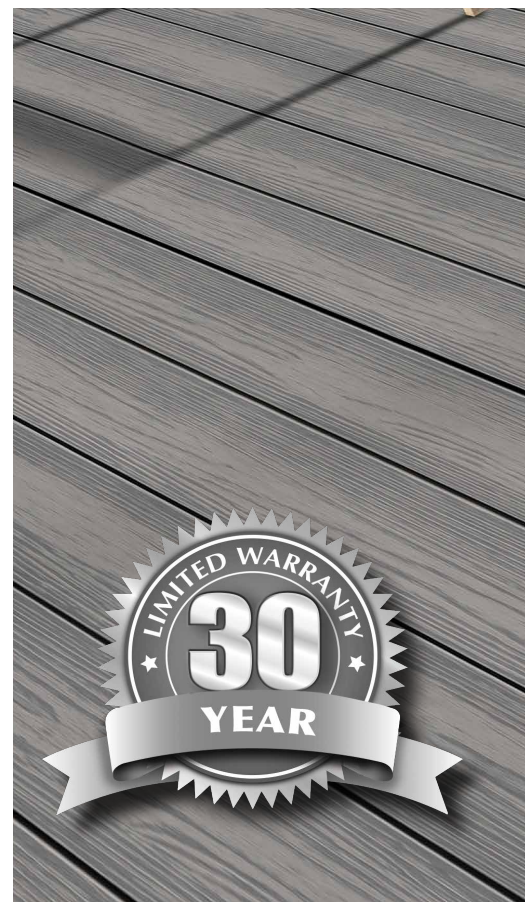



TAKE HOME THE BENEFITS



INCREASED SPAN

Reinforcement improves strength & span capability



MORE STABLE

Less movement from expansion & contraction



NATURAL AESTHETIC

Advanced technology for more natural looking composite



SLIP RESISTANT

Reliable slip resistance properties



LOW-MAINTENANCE

Only basic care required for optimal longevity



PROTECTIVE CAP

Fade, scratch, & stain resistant capping technology



DECAY RESISTANT

Resists insects, moisture, & weather



ECO-FRIENDLY

Long-lasting & prevents deforestation

REINFORCED, CAPPED BAMBOO-PVC COMPOSITE



140 x 24 mm
Grooved both sides



140 x 24 mm
Rectangular profile

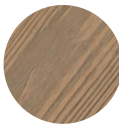

SCULPTED GRAIN

GFR / GLASS FIBER REINFORCED



SCULPTED GRAIN

GFR / GLASS FIBER REINFORCED

GROOVED BOARD

The Apex PLUS single sided grooved board in bamboo-foamed PVC with a glass fiber-reinforced core offers a flawless, fastener-free final look thanks to the grooves along its edges which are designed for streamlined installation using HULK hidden fastener clips.

Dimensions	140 x 24 mm (5,45 m lengths)
Weight	2.9 kg/m
Recommended Joist spacing	450 mm centre to centre

Grooved board



Fasteners



Compatible with Chain collated clips

SQUARE EDGE BOARD

The Apex PLUS single sided square edge board in bamboo-foamed PVC with a glass fiber-reinforced core is designed for straightforward installation using HULK colour matching top fixing screws, and a multitude of creative application options, from decking to cladding, edging to screening.

Dimensions	140 x 24 mm (5,45 m lengths)
Weight	3.0 kg/m
Recommended Joist spacing	450 mm centre to centre

Square edge board

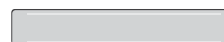

Fasteners



Uses HULK composite top fixing screws on non-grooved edges



Apex[®] PLUS

FINISH & COLOUR GUIDE

Apex PLUS offers a carefully crafted dual tone colour range which adds an extra layer of colour to each board to embrace the nuances found in timber and enhance the natural look of your project.



Sculpted Grain
Surface Finish



HIMALAYAN
CEDAR



WESTERN RED
CEDAR



BRAZILIAN
TEAK



ALASKAN
DRIFTWOOD

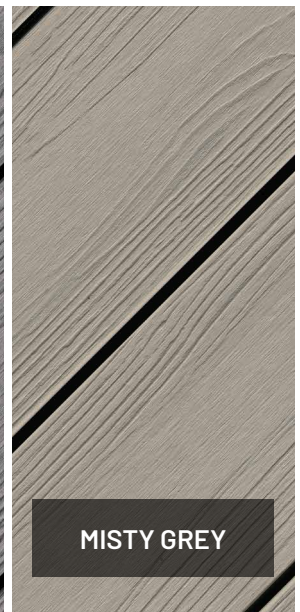

MISTY GREY

NOTE: Due to printing and/or screen variations, colours in the brochure may differ slightly from the actual products.

Apex

LIGHTWEIGHT, CAPPED BAMBOO-PVC COMPOSITE

Apex offers you a resilient and natural looking composite. Its ultra-lightweight bamboo foamed-PVC core makes for easy installation and workability. Apex carries both fire and slip resistance ratings and exceptional low maintenance, requiring only basic cleaning for optimal longevity. Its protective cap is made from a resilient acrylic polymer coating for fade, scratch, and stain resistance. Apex provides long-term decay and weather protection by resisting insects, moisture, and the elements. Apex is an eco-friendly alternative to timber that prevents deforestation and premature deck replacement and uses solar power within the manufacturing process.

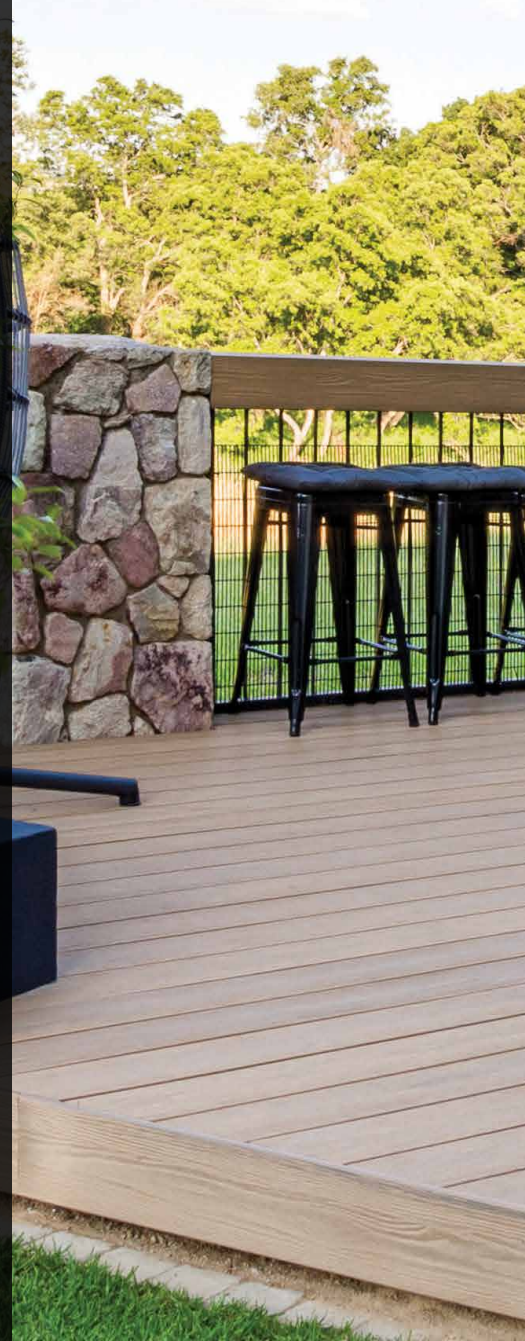

PRODUCT COMPOSITION



Apex products are lightweight thanks to their foamed bamboo-PVC composite core which is protected from the elements by a resilient acrylic polymer capping.



Capping material:
Engineered acrylic polymer

Core material:
Bamboo foamed-PVC composite



FSC certified bamboo composite product



EUROCLASS B_{fl} - s1
FIRE RATED





TAKE HOME THE BENEFITS



NATURAL AESTHETIC

Advanced technology for more natural looking composite



LIGHTWEIGHT

Ultra-lightweight bamboo-PVC core



FIRE RESISTANT

Euroclass B_{f1} - s1 fire rated



SLIP RESISTANT

Reliable slip resistance properties



LOW-MAINTENANCE

Only basic care required for optimal longevity



PROTECTIVE CAP

Fade, scratch, & stain resistant capping technology



DECAY RESISTANT

Resists insects, moisture, & weather



ECO-FRIENDLY

Long-lasting & prevents deforestation

LIGHTWEIGHT, CAPPED BAMBOO-PVC COMPOSITE



140 x 24 mm
Grooved both sides



140 x 24 mm
Rectangular profile



SCULPTED GRAIN

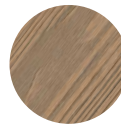

SCULPTED GRAIN

GROOVED BOARD

The Apex single sided grooved board installs efficiently and securely with CHAIN collated clips which slot into the grooves along the edges of the board and create an uninterrupted final look.

Dimensions	140 x 24 mm
Weight	2.5 kg/m
Recommended Joist spacing	300 mm centre to centre

STARTER BOARD

The Apex single sided starter board offers one grooved edge and one solid edge, making it perfect for deck perimeters, picture framing decks, and creating stairs. It fastens with a combination of CHAIN collated clips and colour matched HULK composite decking screws.

Dimensions	140 x 24 mm
Weight	2.5 kg/m
Recommended Joist spacing	300 mm centre to centre

Grooved board



Fasteners



Compatible with Chain collated clips

Starter board



Fasteners



Compatible with Chain collated clips



Uses HULK composite top fixing screws on non-grooved edges



Apex

FINISH & COLOUR GUIDE

The dual tone range of Apex adds an extra layer of colour to each board to enhance the natural look of your composite project. The variance in shades within a single composite profile beautifully showcases the colour tones found in timber making your composite all the more striking. Dual tone colours are ideal for mid-to-large-scale composite decks and projects or other areas that are all about that natural look.

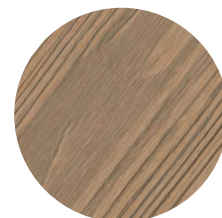

Sculpted Grain
Surface Finish



HIMALAYAN
CEDAR



WESTERN RED
CEDAR



BRAZILIAN
TEAK

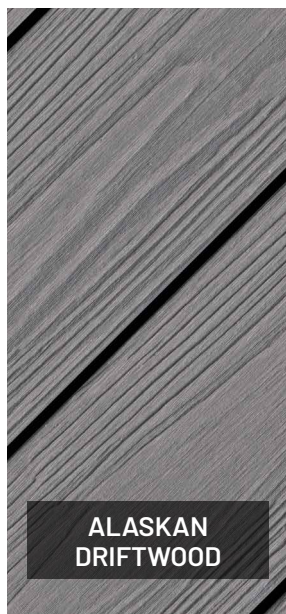

ALASKAN
DRIFTWOOD

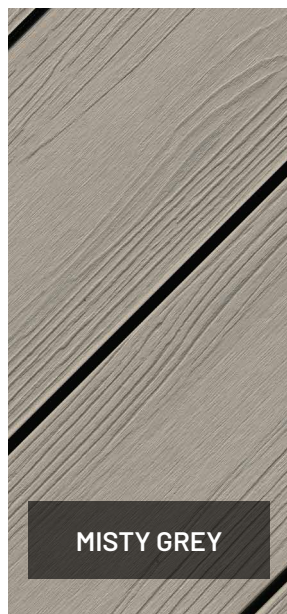

MISTY GREY

NOTE: Due to printing and/or screen variations, colours in the brochure may differ slightly from the actual products.

Apex



LIGHTWEIGHT, CAPPED BAMBOO-PVC COMPOSITE



150 x 12 mm
Rectangular profile



SCULPTED GRAIN

FASCIA BOARD

Apex fascia boards are non-load bearing profiles that help to add a neat finish to deck sides or areas where trim is needed. They are fastened using colour matching HULK top fixing composite trim screws.

Dimensions	150 x 12 mm
Weight	1.4 kg/m
Recommended Joist spacing	300 mm centre to centre* <i>*Based on non-load bearing applications only</i>

Fascia board



Fasteners



Uses HULK composite trim screws

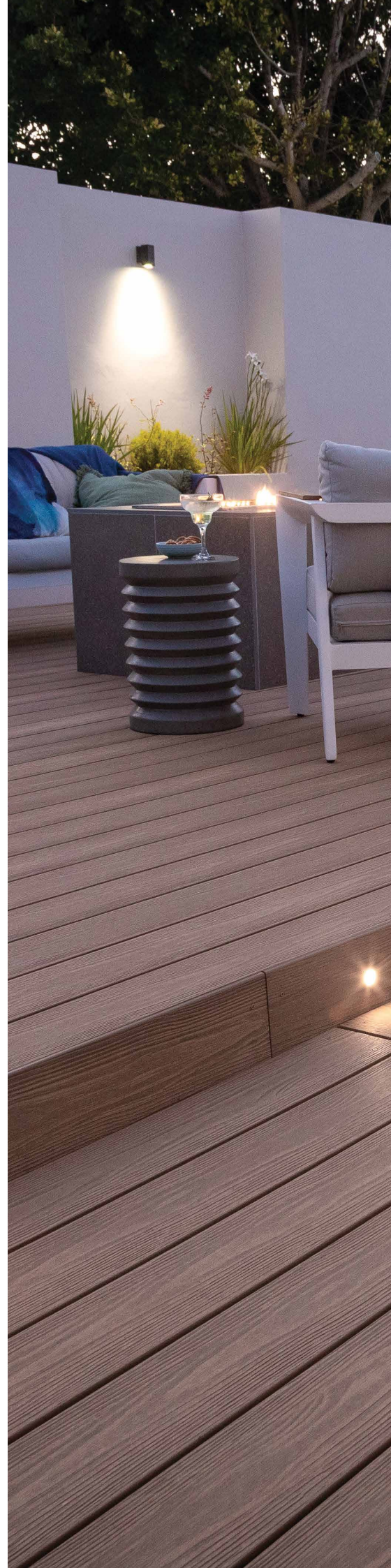



Infinity IS

LIGHTER WEIGHT, CAPPED BAMBOO COMPOSITE DECKING

Infinity IS combines all the benefits of Infinity bamboo composite with the advantages of I-Series to give you a durable co-extruded composite. With Infinity IS specialised streaked colour variation technology, you can enjoy the look of timber and the environmental benefits of bamboo composite. The newly optimised I-beam design creates a highly cost-effective board that uses less material yet maintains the performance and longevity we have come to expect from Infinity bamboo composite. The lighter weight of this optimised profile assists with a more efficient transportation and installation.

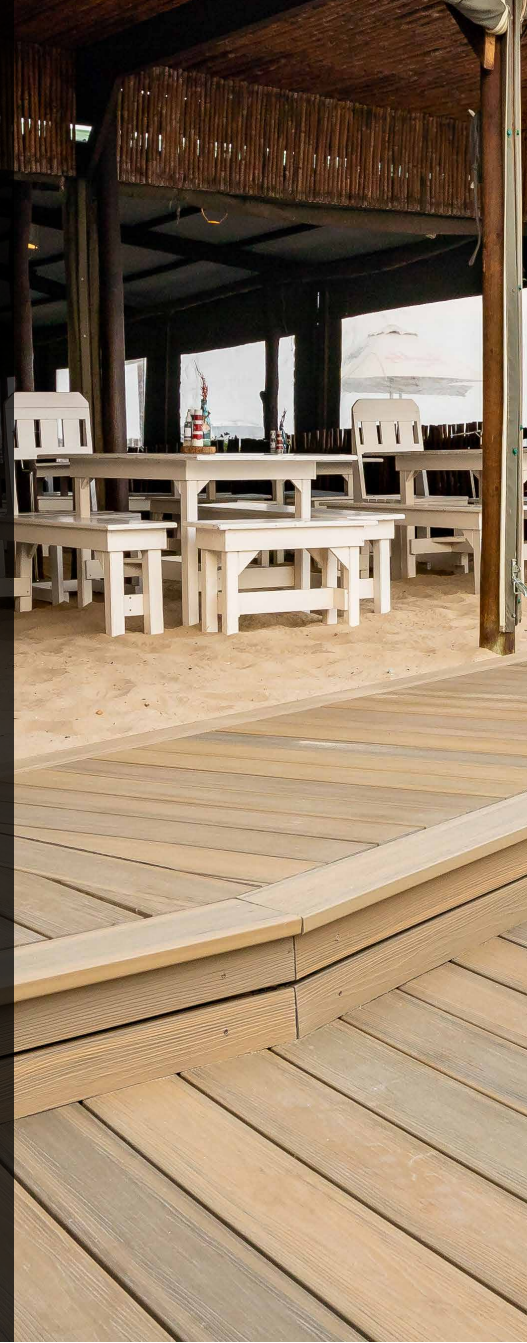

PRODUCT COMPOSITION



Infinity bamboo composite decking adds value and good looks to your outdoor space and to your lifestyle by giving you steadfast decking that lasts for decades.

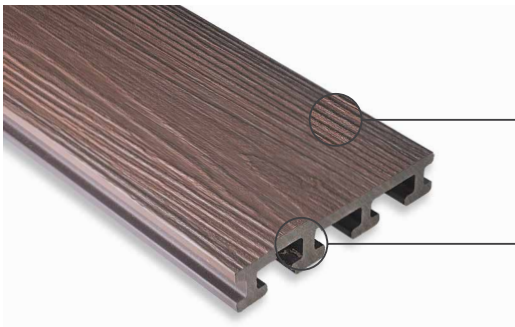

(P) PATENTED TECHNOLOGY

Capping material:
Engineered polymer

Core material:
Bamboo PE composite



FSC® certified bamboo composite product





TAKE HOME THE BENEFITS



DURABLE

One of the toughest co-extruded composites



PROTECTIVE CAP

Fade, scratch, & stain resistant capping technology



LOW-MAINTENANCE

Only basic care required for optimal longevity



DECAY RESISTANT

Resists insects, moisture, & weather



NATURAL LOOK

Specialised streaked colour technology



COST-EFFECTIVE

Smart shape saves on transport & installation



LIGHTWEIGHT

I-beam design is lighter by using less material

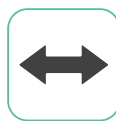

SPAN

Span capability of heavier boards



INSTALLATION

Easier and more efficient installation



ECO-FRIENDLY

Sustainable manufacturing & use of raw material

LIGHTER WEIGHT, CAPPED BAMBOO COMPOSITE DECKING



134 x 25.4 mm
Grooved both sides



SCULPTED GRAIN

GROOVED BOARD

The exceptionally lightweight Infinity IS single sided grooved board installs efficiently and securely with CHAIN collated clips which slot into the grooves along the edges of the board and create a neat uninterrupted final look.

Dimensions	134 x 25.4 mm
Weight	2.4 kg/m
Recommended Joist spacing	300 mm centre to centre

Grooved board



Fasteners



Compatible with Chain collated clips



134 x 25.4 mm
Grooved one side

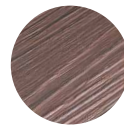

SCULPTED GRAIN

STARTER BOARD

The exceptionally lightweight Infinity IS single sided starter deck board offers one grooved edge and one solid edge, making it perfect for deck perimeters, picture framing decks, and creating stair edges. It fastens with a combination of CHAIN collated clips and colour matched HULK composite decking screws.

Dimensions	134 x 25.4 mm
Weight	2.4 kg/m
Recommended Joist spacing	300 mm centre to centre

Starter board



Fasteners



Compatible with Chain collated clips



Uses HULK composite top fixing screws on non-grooved edges



Infinity

FINISH & COLOUR GUIDE

The Infinity range is designed to enhance the beauty and liveability of your outdoor area. Infinity composite offers incredibly natural-looking colours thanks to its advanced colour technology which gives each board unique colour variation to embody the essence of timber. Enjoy the beauty of wood with the benefits of composite.



**Sculpted Grain
Surface Finish**

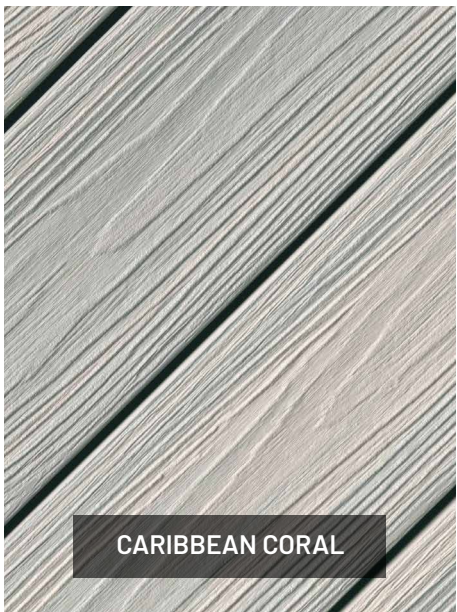

CARIBBEAN CORAL

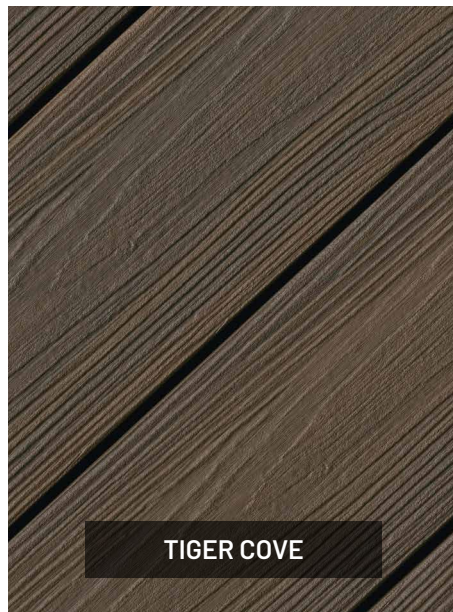

TIGER COVE

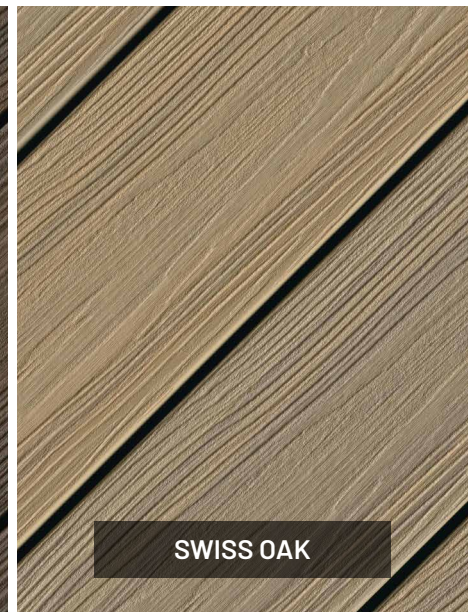

SWISS OAK

NOTE: Due to printing and/or screen variations, colours in the brochure may differ slightly from the actual products.

CAPPED BAMBOO COMPOSITE FASCIA



150 x 12 mm
Rectangular profile



SCULPTED GRAIN

FASCIA BOARD

The Infinity single sided fascia boards are non-load bearing profiles that add a neat finish to deck edges or areas where trim is needed. They are neatly fastened by top fixing colour matching HULK composite trim screws.

Dimensions	150 x 12 mm
Weight	2.3 kg/m
Recommended Joist spacing	300 mm centre to centre* <i>*Based on non-load bearing applications only</i>

Fascia board



Fasteners



Uses HULK composite trim screws





Origins

CAPPED BAMBOO COMPOSITE DECKING

Origins bamboo composite by Eva-Last combines the beauty of timber, the sustainability of bamboo, and the long-term reliability of low-maintenance co-extruded protective capping to bring you a more cost-effective and convenient option for your decking and cladding. Elevate your outdoor space while lowering your environmental impact and your time spent on upkeep.

PRODUCT COMPOSITION



Origins offers an environmentally conscious, and low-maintenance product. It is produced using holistically sustainable manufacturing practices and uses recycled PE plastic and sustainable bamboo at its core.



Capping material:

Protective co-extruded polymer cap

Core material:

Bamboo PE composite



FSC® certified bamboo composite product





TAKE HOME THE BENEFITS



LOW-MAINTENANCE



STAIN RESISTANT



WEATHER & DECAY
RESISTANT



FADE RESISTANT



NATURAL LOOK



ENVIRONMENTALLY
FRIENDLY

LIGHTWEIGHT BAMBOO COMPOSITE DECKING



136 x 21.5 mm
Grooved both sides

GROOVED BOARD

Origins hollowcore grooved board installs efficiently and securely with the Chain collated clips. This profile offers a capped woodgrain finish to give you a timber looking deck.

Dimensions	136 x 21.5 mm
Weight	2.6 kg/m
Recommended Joist spacing	300 mm centre to centre



WOODGRAIN FINISH

Grooved board



Fasteners



Compatible with Chain collated clips

ORIGINS COLOUR GUIDE

The Origins colour range stands as testament to the beauty of nature. Each colour has the subtle variations and tones of a specific timber shade and is presented in a matte finish. The artfully designed surface finish gives the texture of wood grain to enhance the natural look of each board. The Origins colour range can be customised to suit the specific requests of your target market.

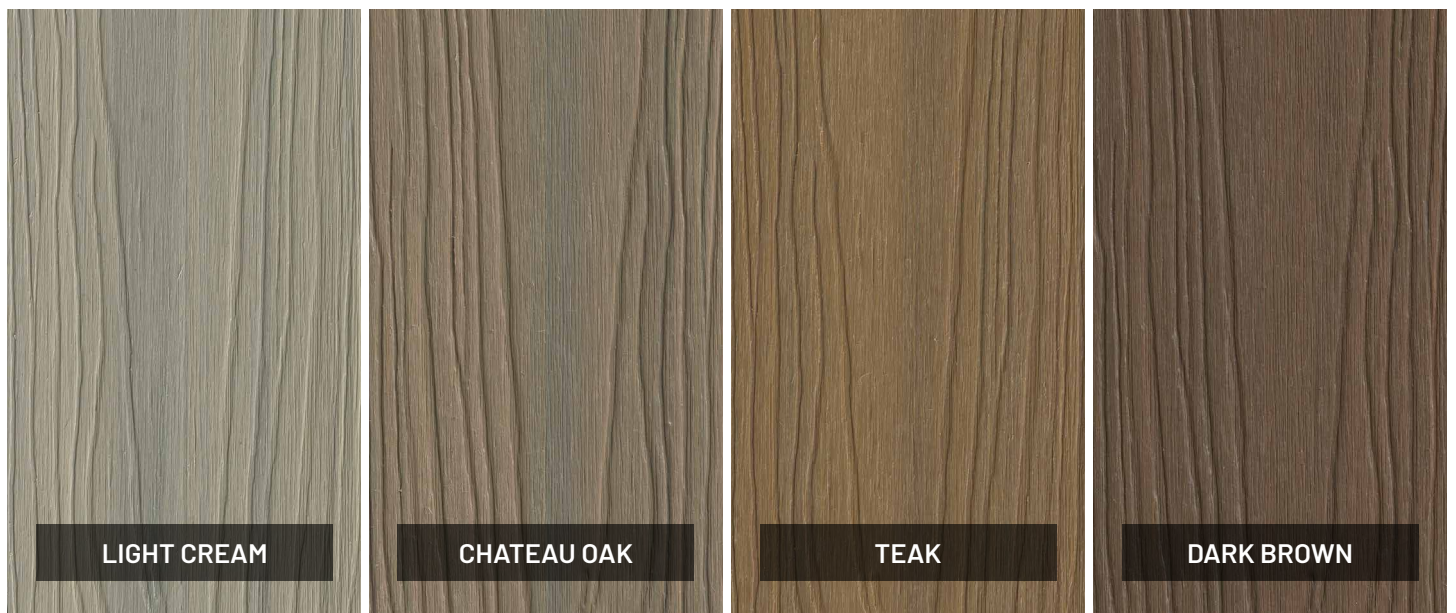

LIGHT CREAM

CHATEAU OAK

TEAK

DARK BROWN



LIFESPAN

COMPOSITE ARCHITECTURAL BEAMS

HYBRID ALUMINIUM BAMBOO COMPOSITE BEAM

Lifespan hybrid aluminium composite beams give you the creative freedom to build more memorable outdoor architectural designs. These multipurpose beams have the functionality, resiliency, and beauty to make your project remarkable. Whether you choose to use Lifespan beams for pergolas, entryways, dramatic screening, or your own creative architectural vision, revel in the feeling of building something truly innovative.



HIGH PERFORMANCE FOR HIGH EXPECTATIONS

Lifespan beams add style and functionality in a diverse range of applications. Enjoy the shade and privacy of a pergola or screen, or enhance the appeal of your home exterior with beams that give the look of wood without the maintenance hassles. The versatility of Lifespan decorative architectural beams is matched only by their beauty.



PERGOLAS



PRIVACY SCREENS

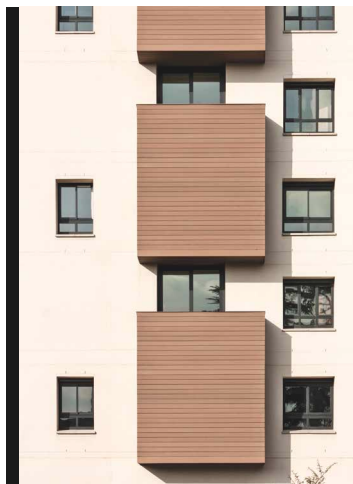

CLADDING & SOFFITS



DECORATIVE ARCHITECTURE



TAKE HOME THE BENEFITS



DESIGN VERSATILITY

Architectural beams offer a diverse range of aesthetic applications



LIGHTWEIGHT DESIGN

Specialised aluminium core for easier installation at height



LOW-MAINTENANCE

The look of timber beams without the upkeep



INCREASED SPAN

Reinforced bamboo composite beam with built-in aluminium core



DECAY & WEATHER RESISTANT

Resists biodegradation, corrosion, insects, & harsh weather



FADE RESISTANT

Built-in UV protection for beautiful durability



LIFESPAN

COMPOSITE ARCHITECTURAL BEAMS

REINFORCED MODULAR COMPOSITE

Lifespan architectural beams offer design versatility and increased span thanks to their specialised aluminium core that makes for easier installation at height. The outer coating of low-maintenance bamboo composite resists biodegradation, corrosion, insects, and harsh weather, and offers built-in UV protection for beautiful durability. Enjoy the look of timber beams without the upkeep.

TRI-EXTRUDED ALUMINIUM BAMBOO COMPOSITE

- 1 Aluminium core
- 2 Engineered flexible adhesive
- 3 Outer protective composite coating (Eva-tech surface technology)



INCREASED SPAN

Lifespan architectural beams offer the span capability of much heavier, solid beams thanks to their built-in aluminium core. This core significantly enhances the dimensional and flexural stability of the beam, while the Eva-tech bamboo composite coating provides a realistic timber aesthetic, as well as resistance to severe climatic and biodeterioration conditions.



PROFILE SIZE OPTIONS

Lifespan hybrid aluminium composite beams are available in a range of sizes and shapes to suit your outdoor project design. Lifespan has been designed to meet industrial norms. However, building codes and standards may differ between jurisdictions or countries. Be sure to consult your local building codes before installing Lifespan composite beams.

Dimensions: 50 x 30 mm
Weight: 0.8 kg/m



Dimensions: 100 x 30 mm
Weight: 1.3 kg/m



Dimensions: 150 x 35 mm
Weight: 2.6 kg/m



Dimensions: 150 x 50 mm
Weight: 3.3 kg/m



End caps



End caps and post caps are available allowing for a neat finish to your Lifespan composite beams.

TRI-EXTRUDED ALUMINIUM BAMBOO COMPOSITE



50 x 30 mm

DECORATIVE BEAM

The 50 x 30 mm Lifespan decorative profile enhances your outdoor space with the look of a traditional timber baluster. This compact batten sized profile is a popular choice for creating durable screens, gates, pergolas and other low-maintenance outdoor architectural features.

Available in Eva-tech colour range

Dimensions	50 x 30 mm
Standard length	5,8 m
Weight	0.8 kg/m

Hollow aluminium composite beam



End caps available

Colour matched end caps create a finished look on beam ends.



100 x 30 mm

DECORATIVE BEAM

The 100 x 30 mm Lifespan decorative profile is a fan favourite in the Lifespan range, ideal for creating striking and durable outdoor pergolas, beams, privacy screens, or other attractive architectural features. Enjoy the look of timber beams without the upkeep and environmental toll.

Available in Eva-tech colour range

Dimensions	100 x 30 mm
Standard length	5,8 m
Weight	1.3 kg/m

Hollow aluminium composite beam



End caps available

Colour matched end caps create a finished look on beam ends.



PHOTOGRAPHY CREDIT: PATRICK KING PHOTOGRAPHY
COPYRIGHT © RADISSON RED HOTEL - ALL RIGHTS RESERVED.

TRI-EXTRUDED ALUMINIUM BAMBOO COMPOSITE



DECORATIVE BEAM

The 150 x 35 mm Lifespan decorative beam adds a sense of drama to your outdoor space with its uniquely broad but still slim dimensions. Create the perfect privacy screen or embrace the aesthetic of composite beams as a pergola or other outdoor decorative features.

Available in Eva-tech colour range

Dimensions	150 x 35 mm
Standard length	5,8 m
Weight	2.6 kg/m

Hollow aluminium composite beam



End caps available

Colour matched end caps create a finished look on beam ends.



DECORATIVE BEAM

The 150 x 50 mm Lifespan decorative beam is a larger rectangular profile in the Lifespan range and creates a stately aesthetic for your outdoor space, ideal for use as an oversized pergola beam, privacy screen, or in conjunction with smaller Lifespan beams within the system.

Available in Eva-tech colour range

Dimensions	150 x 50 mm
Standard length	5,8 m
Weight	3.3 kg/m

Hollow aluminium composite beam



End caps available

Colour matched end caps create a finished look on beam ends.



TECHNOLOGY: **Eva-tech** 

LIFESPAN IN EVA-TECH COLOUR TECHNOLOGY



Brushed
Surface Finish

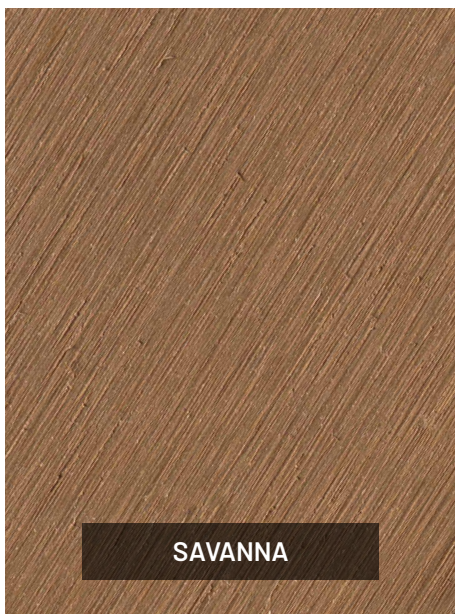

SAVANNA

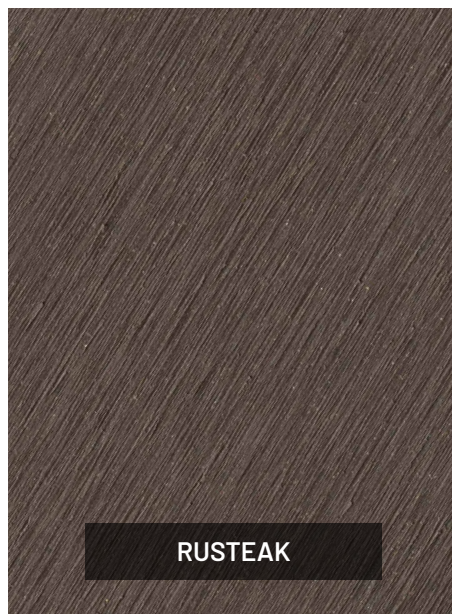

RUSTEAK



XAVIA

NOTE: Due to printing and/or screen variations, colours in the brochure may differ slightly from the actual products.

HULK FASTENERS.

RELIABLE DECKING FASTENER SYSTEMS

HULK Fasteners are purposefully designed to make composite or timber decking installations more efficient and straightforward by providing highly durable hidden fastener options that fit neatly into the edges of grooved boards, as well as a range of colour matching top fixing screws. These fasteners are created to match the warranties of the leading composite decking boards on the market, and are available in a range of colours to complement the look of your decking of choice.



DESIGNED FOR PROFESSIONALS. PERFECT FOR NOVICES.

HULK Fasteners offer higher performance and are a more efficient and subtle way to secure your decking and trim boards without disrupting its final look.

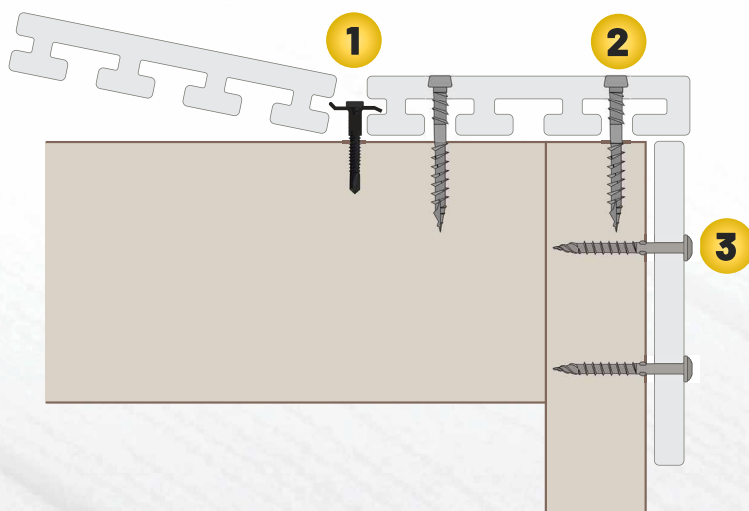

- 1** Chain Collated Clips
- 2** Composite Decking Screw (CDS) for timber frames or Metal Decking Screw (MDS) for metal frames
- 3** Composite Trim Screw for timber frames or Metal Trim Screw for metal frames



TAKE HOME THE BENEFITS

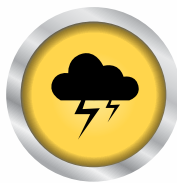

**Corrosion
Resistant**



**Colour Matched
Aesthetic**



**Neat Surface
Finish**



**Fast and Easy
Installation**



**No Pre-drilling
Required**

chain

Collated decking clip

UNIVERSAL COLLATED HIDDEN DECK FASTENER

Chain collated clips are innovatively engineered to work with composite or timber boards of varying thickness and with timber or metal frames for a more cost-effective and efficient installation. Chain offers superior durability and strength, a discreet appearance, and easier post-installation access and board removal.

A PRODUCT BY  **HULK FASTENERS.**



GET THE JOB DONE FASTER.

Chain collated clips save you time and money by streamlining installation with pre-loaded screws that offer cutting-edge performance for the entire lifespan of your deck. Enjoy a simpler installation and a more secure long-term fastener that complements the overall look of your deck.

Stainless steel clip with
polymer coating

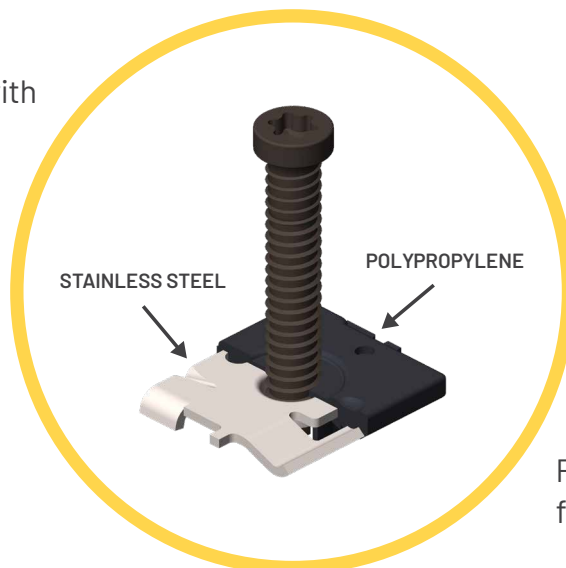

Pre-loaded with screw
for ease of installation

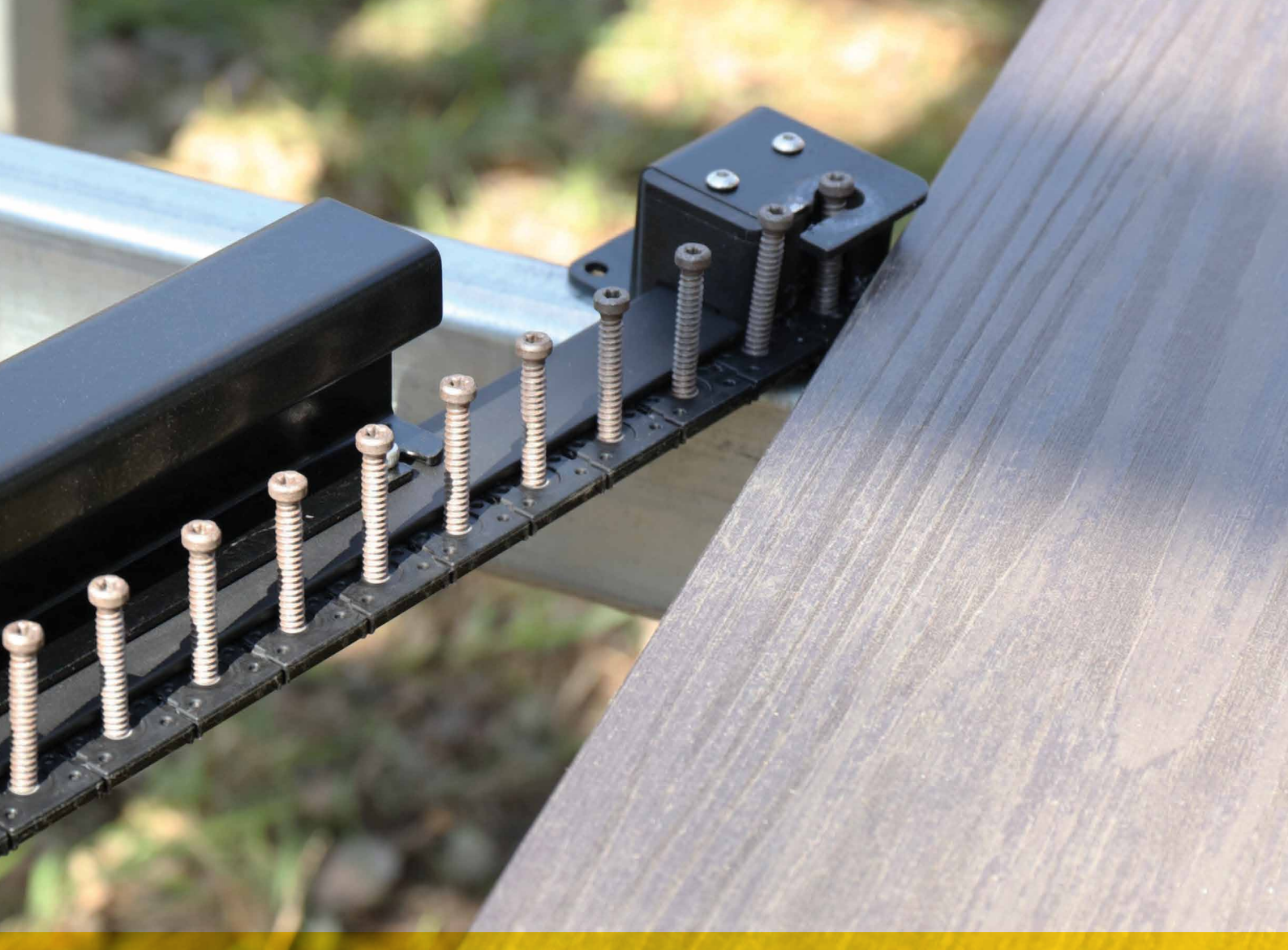

FEATURES AND BENEFITS



MORE EFFICIENT INSTALLATION

Collated system comes pre-loaded with screws for quicker installation



UNIVERSAL APPLICATION

Works with timber & composite boards of variable thickness & groove depths



DURABLE

Stainless steel clip with a protective polymer coating for extended outdoor longevity



STRENGTH IN SIZE

Proven strength in uplift holding power & preventing lateral movement of boards



INNOVATIVE ENGINEERING

Cost-effective use of materials without affecting grip strength or overall clip performance



EASIER POST-INSTALLATION ACCESS

More convenient post-installation board removal with direct overhead fastener access



chain

Collated decking clip

new

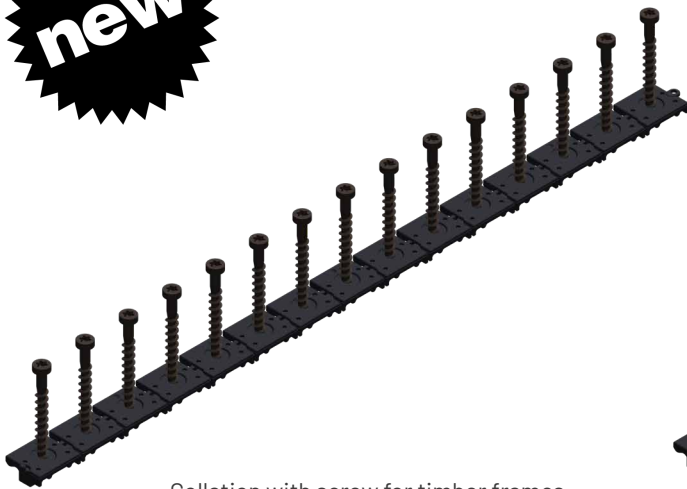

Collation with screw for timber frames

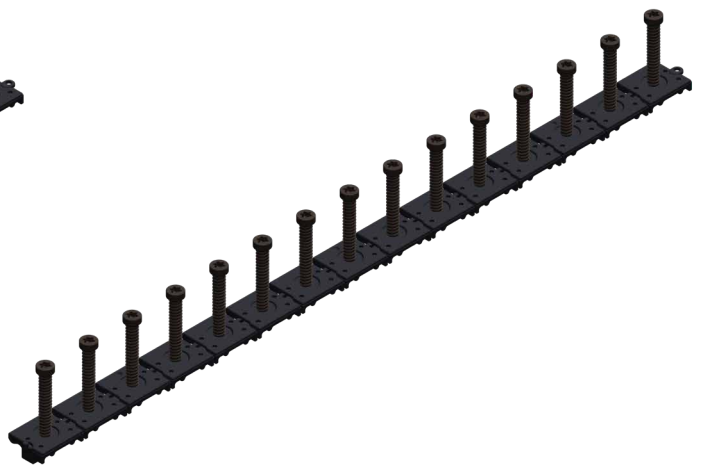

Collation with screw for metal frames

CHAIN COLLATED CLIPS

Chain collated clips offer a smarter solution for creating an outdoor oasis. By preloading high quality and durable screws into equally reliable clips. Chain collated clips make installation more efficient, and are suitable for use by professionals or novices. Like all Eva-Last products, Chain collated clips are built on the principle of longevity.

CHAIN PACK



900 Chain COLLATED CLIPS

Six boxes in a pack; 150 clips per box

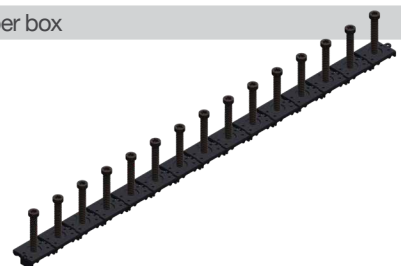



chain

COLLATED CLIP HAND TOOL

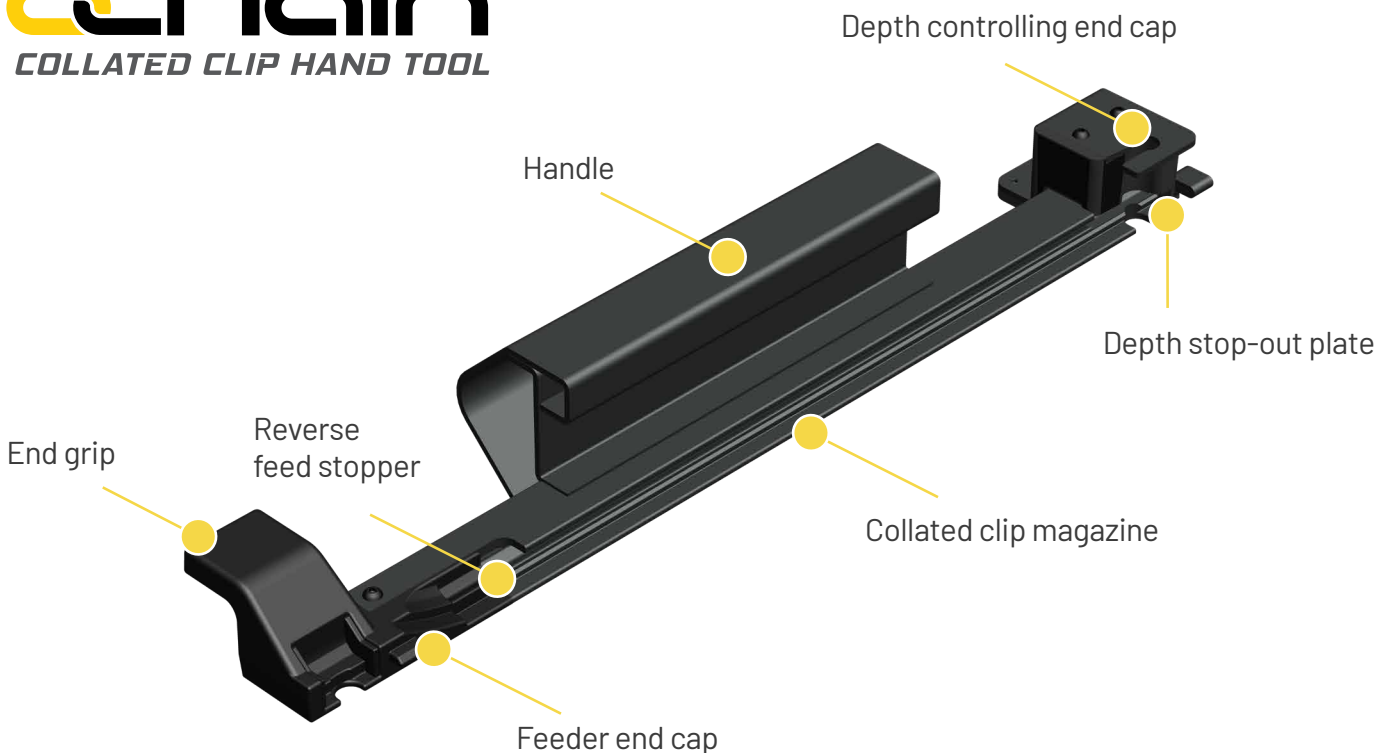

CHAIN HAND TOOL

The Chain hand tool adds value to the Chain collated clip system by maximising installation efficiency. The hand tool creates precise fastening thanks to its built-in depth control system that eliminates installation errors and weak connections. The hand tool is compatible with a wide range of composite and timber board sizes, ergonomically designed for ease of use, and made from high quality materials for long-lasting reliability.

EXPANSION KITS



1 Chain HAND TOOL

- 1 collated clip hand tool
- 1 T15 (50 mm) depth setting bit



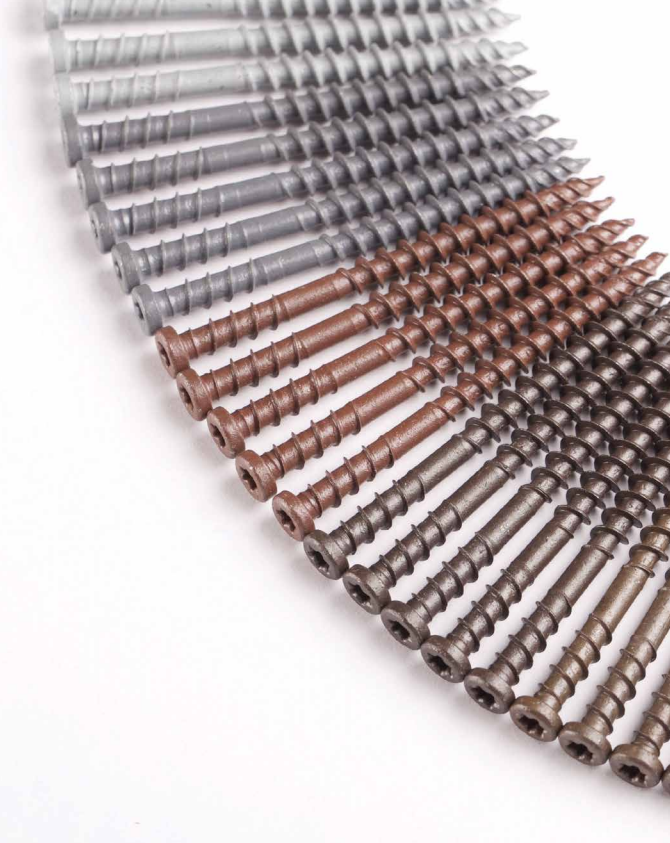

COLOUR MATCHED COMPOSITE TOP FIXING SCREWS

HULK Fasteners composite deck and trim screws are available in nine different colours designed to match and blend in with decking boards from all leading composite decking manufacturers. Choose the colour that matches your decking boards for a discreet final look. Please check your regional availability of screw colours.

FOR TIMBER FRAMES

Available in stainless steel and carbon steel

FOR METAL FRAMES

Available in carbon steel

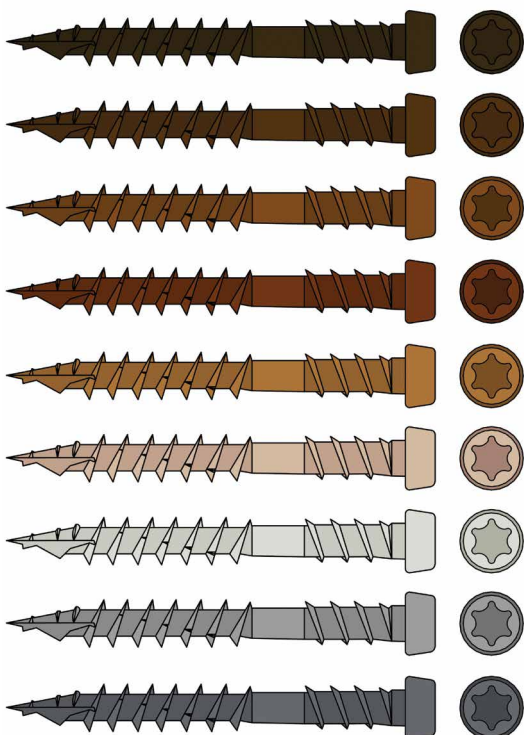

DARK BROWN

BROWN

LIGHT BROWN

RED BROWN

TAN BROWN

BEIGE

WHITE

LIGHT GREY

DARK GREY

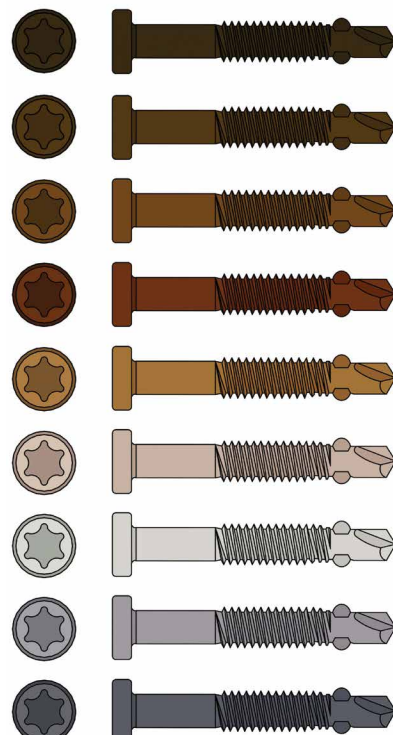

COMPOSITE DECKING SCREWS

CDS - Composite Deck Screw

For fastening (top-fixing) composite boards to timber frames



Carbon steel: fully coated
Available in dark brown, light brown, brown, red brown, tan brown, beige, dark grey, light grey, and white



Stainless steel: 316 head coated
Available in dark brown, light brown, brown, red brown, tan brown, beige, dark grey, light grey, and white

MDS - Metal Deck Screw

For fastening (top-fixing) composite boards to metal frames



Carbon: 2 000 hour coating
Available in dark brown, light brown, brown, red brown, tan brown, beige, dark grey, light grey, and white

75 COMPOSITE DECK SCREWS (for timber or metal frames)



75 Pack TOP FIXING SCREWS

75 carbon steel or stainless steel composite deck screws
1 drill bit



HULK Fasteners are recommended for use with all Eva-Last installations. HULK composite deck and trim screws are available for timber and metal frames.

150 COMPOSITE DECK SCREWS (for timber or metal frames)



150 Pack TOP FIXING SCREWS

150 carbon steel or stainless steel composite deck screws
1 drill bit



HULK Fasteners are recommended for use with all Eva-Last installations. HULK composite deck and trim screws are available for timber and metal frames.



COLOUR MATCHED COMPOSITE TRIM SCREWS

HULK Fasteners trim screws are specially engineered to fasten composite trim boards or fascia boards to a structure. Choose between the composite trim screws designed to work with timber substructures and composite trim screws created to work with metal substructures. Each type of trim screw offers unique dimensions for use with either wood or metal framing, but both types of trim screws are available in stainless steel and carbon steel and in a wide range of colours to match your composite fascia or trim boards.

FOR TIMBER FRAMES

Available in stainless steel and carbon steel

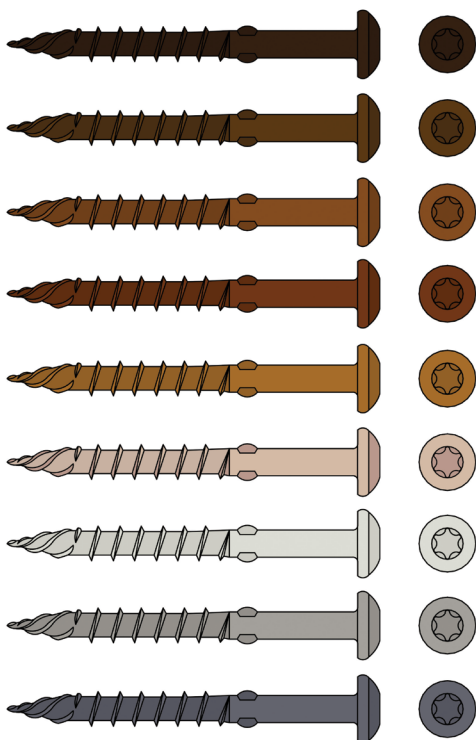

DARK BROWN

BROWN

LIGHT BROWN

RED BROWN

TAN

BEIGE

WHITE

LIGHT GREY

DARK GREY

FOR METAL FRAMES

Available in carbon steel

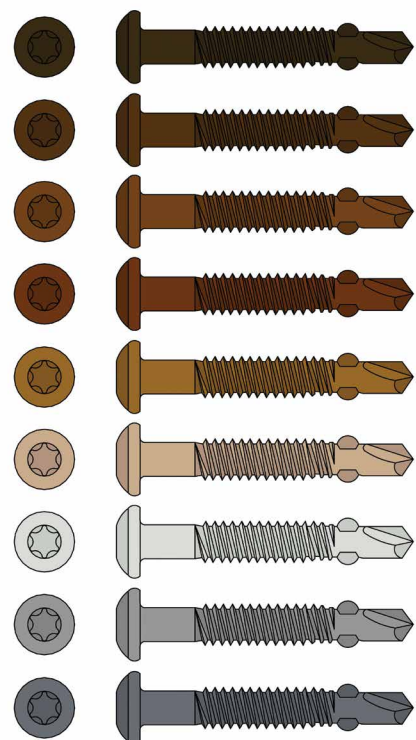

COMPOSITE TRIM SCREWS

M5.5 x 48 mm composite trim screws
for use with timber frames



M5.5 x 35 mm composite trim screws
for use with metal frames

75 COMPOSITE TRIM SCREWS (for timber or metal frames)



75 Pack TOP FIXING SCREWS

75 carbon steel or stainless steel composite trim screws
1 drill bit



HULK Fasteners are recommended for use with all Eva-Last installations. HULK composite deck and trim screws are available for timber and metal frames.

150 COMPOSITE TRIM SCREWS (for timber or metal frames)



150 Pack TOP FIXING SCREWS

150 carbon steel or stainless steel composite trim screws
1 drill bit



HULK Fasteners are recommended for use with all Eva-Last installations. HULK composite deck and trim screws are available for timber and metal frames.

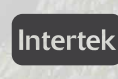

LOW ENVIRONMENTAL IMPACT

Holistically sustainable manufacturing & use of raw materials

CHOOSE SUSTAINABLE BUILDING MATERIALS



RENEWABLE RESOURCES & RENEWABLE ENERGY

We believe that how we manufacture is just as important as what we manufacture when it comes to going green. That's why we've traded in fossil fuels for renewable energy. Our products use solar power as part of our manufacturing process. We are fully committed to bringing you a product that's holistically sustainable.

Every Eva-Last outdoor range pairs recycled raw ingredients with bamboo for a stronger, more sustainable composite. Bamboo rejuvenates over 30 times faster than traditional hardwoods and it releases 35% more oxygen into our air. Eva-Last is internationally recognised for our commitment to the environment. We're proud of the work we do to promote environmental sustainability, and invite you to choose timber alternatives that are gentle on the Earth.

- Made from recycled materials
- No trees felled
- No treatment or toxic chemicals required for maintenance
- Solar power used in the manufacturing process
- Reduced impact on landfills
- Reduced carbon footprint



Teléfono: 983 218470 | www.masmadera.eu

Más Madera Flooring Group S.L.

C/ Topacio, 15 (Polígono San Cristóbal)
47012 Valladolid



www.eva-last.es